

**FORGED CARBON STEEL A350LF2 GLOBE VALVE CLASS 800 TRIM 12 BOLTED BONNET**



ISO 9001 : 2015



PED 2014/68/EU



**Certificate 3.1**

**Size :** DN 15 to 50 (NPS 1/2" to 2")  
**Ends :** Female - Female NPT, Socket Welding  
**Min Temperature :** - 46°C  
**Max Temperature :** + 425°C  
**Max Pressure :** 136 Bars (Class 800)  
**Specifications :** Rising rotating stem (OS&Y)  
Bolted bonnet  
Full bore

**Materials :** Forged carbon steel A350 LF2

**FORGED CARBON STEEL A350LF2 GLOBE VALVE CLASS 800 TRIM 12 BOLTED BONNET**

**SPECIFICATIONS :**

- Respect the flow direction ( indicated by the arrow )
- Full bore
- Rising rotating stem (OS&Y)
- Bolted bonnet
- Bolted gland pack
- Forged carbon steel ASTM A350 LF2
- 1/2 stellite ( Trim 12 )
- Class 800

**USE :**

- Petroleum industry, steam, high pressure
- Min and max Temperature Ts : - 46°C to + 425°C
- Max Pressure Ps : 136 bars ( see graph )

**FLOW COEFFICIENT Kvs ( M3 / h ) :**

<b>DN</b>	<b>15</b>	<b>20</b>	<b>25</b>	<b>32</b>	<b>40</b>	<b>50</b>
<b>NPS</b>	<b>1/2"</b>	<b>3/4"</b>	<b>1"</b>	<b>1"1/4</b>	<b>1"1/2</b>	<b>2"</b>
<b>Kvs ( m3/h )</b>	<b>3.1</b>	<b>5.7</b>	<b>9.4</b>	<b>12.1</b>	<b>21</b>	<b>34.3</b>

**PRESSURE / TEMPERATURE RELATION :**

<b>Pressure (bar)</b>	<b>136.2</b>	<b>136.2</b>	<b>136.2</b>	<b>124,1</b>	<b>120,7</b>	<b>116,6</b>	<b>110</b>	<b>100,7</b>	<b>98,6</b>	<b>97,9</b>	<b>92,7</b>	<b>75,9</b>
<b>Temperature (°C)</b>	<b>-46</b>	<b>0</b>	<b>38</b>	<b>93,5</b>	<b>149</b>	<b>204,5</b>	<b>260</b>	<b>315,5</b>	<b>343,5</b>	<b>371</b>	<b>399</b>	<b>425</b>

**PRESSURE / TEMPERATURE GRAPH :**

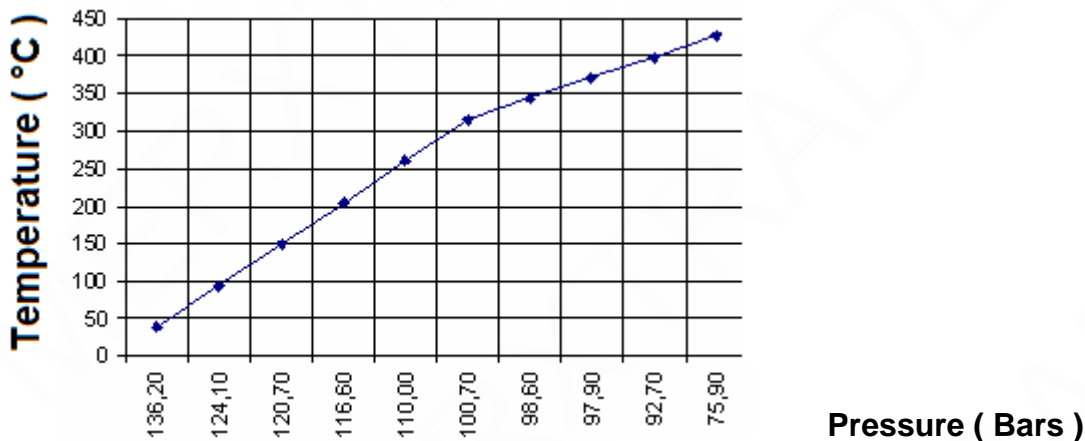

**FORGED CARBON STEEL A350LF2 GLOBE VALVE CLASS 800 TRIM 12 BOLTED BONNET**

**RANGE :**

- Forged globe valve A350LF2 with threaded NPT ends **Ref.418** from DN 15 to 50 ( NPS 1/2" to 2" )
- Forged globe valve A350LF2 with Socket Welding ends **Ref.419** from DN 15 to 50 ( NPS 1/2" to 2" )

**MATERIALS :**

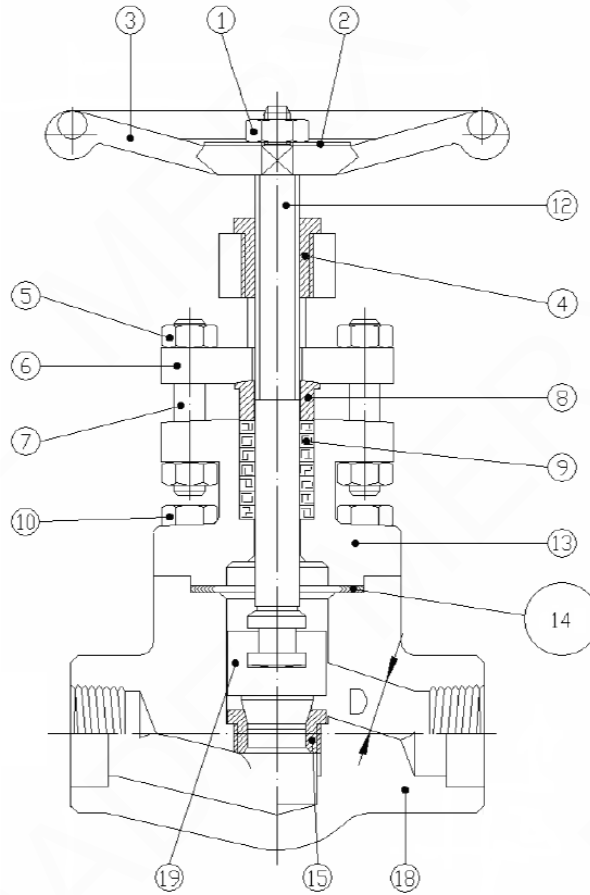

Item	Designation	Materials
1	Handwheel nut	Carbon steel
2	ID plate	Aluminium
3	Handwheel	Carbon steel
4	Yoke nut	ASTM A473 type 416
5	Gland nut	ASTM A194 Gr.4
6	Gland flange	ASTM A182 F6a CI 2
7	Gland stud	ASTM A320 L7
8	Gland	UNS S31600/S31603
9	Packing	Graphite
10	Screw	ASTM A320 L7
12	Stem	ASTM A479 316/316L
13	Bonnet	ASTM A350 LF2
14	Gasket	SS 316 + graphite spiral
15	Seat	ASTM A479 S31600/S31603 Stellite
18	Body	ASTM A350 LF2
19	Disc	ASTM A182 316/316L

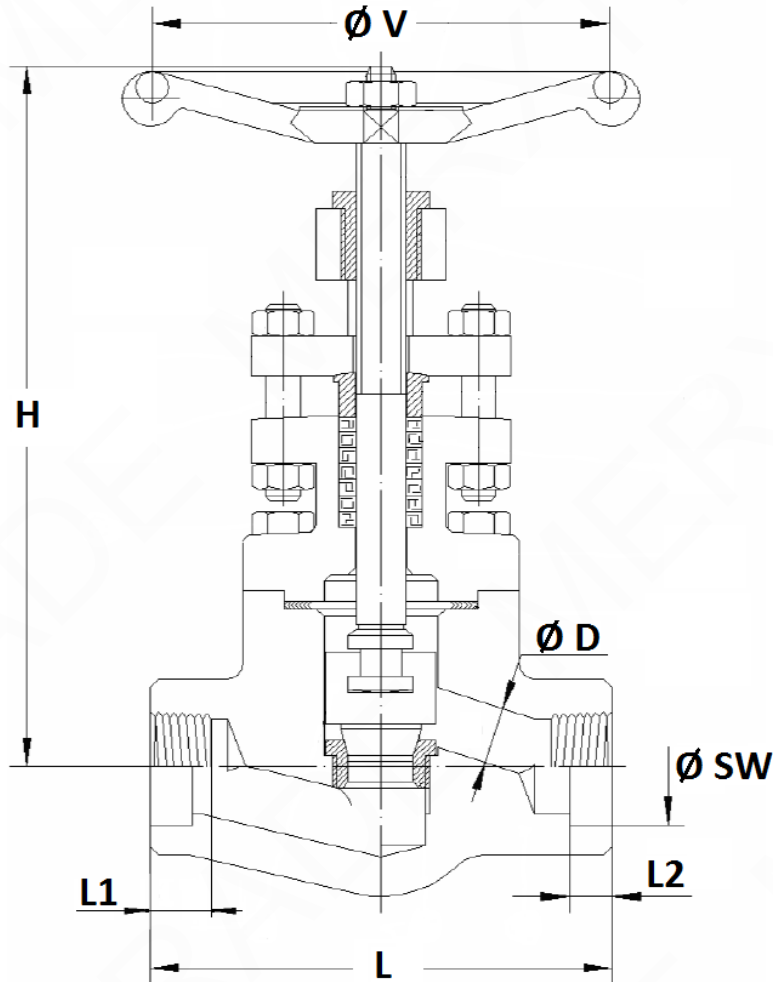
**FORGED CARBON STEEL A350LF2 GLOBE VALVE CLASS 800 TRIM 12 BOLTED BONNET**
**SIZE ( in mm ) :**

Ref.	DN (mm)	15	20	25	40	50
	NPS (")	1/2"	3/4"	1"	1 1/2"	2"
418/419	Ø D	13	17.5	22.5	35	45.5
	L	90	110	127	170	210
	H ( opened )	165	180	213	282	370
	Ø V	80	110	130	180	180
418	L1	15	18	19	21	21
419	L2 ( SW )	12.7	14.5	16	19	22
	Ø SW	21.8	27.2	33.9	48.8	61.2
418/419	Weight (in Kg)	2.2	3.6	5.6	11.4	21

**FORGED CARBON STEEL A350LF2 GLOBE VALVE CLASS 800 TRIM 12 BOLTED BONNET**

**STANDARDS :**

- Fabrication according to **ISO 9001 : 2015**
- **DIRECTIVE 2014/68/EU : CE N° 0036**  
Risk category III module H
- Certificate 3.1 on request
- Designing according to **ISO 15761** and **API 602** 8th
- Pressure Tests according to **API 598, table 6**
- Valves approved by the main oil industries ( certificates on request )
- ATEX Group II Category 2 GD T3 Zone 1 & 21 Zone 2 & 22 ( optional marking ) according to directive 2014/34/EU
- Threaded female NPT ends according to **ANSI B1.20.1**
- Socket Welding ends according to **ISO 15761**

**ADVICE :** Our opinion and our advice are not guaranteed and MXT shall not be liable for the consequences of damages. The customer must check the right choice of the products with the real service conditions.

**FORGED CARBON STEEL A350LF2 GLOBE VALVE CLASS 800 TRIM 12 BOLTED BONNET**

**INSTALLATION INSTRUCTIONS**

**GENERAL GUIDELINES :**

- Ensure that the valves to be used are appropriate for the conditions of the installation (type of fluid, pressure and temperature).
- Be sure to have enough valves to be able to isolate the sections of piping as well as the appropriate equipment for maintenance and repair.
- Ensure that the valves to be installed are of correct strength to be able to support the capacity of their usage.
- **Installation of all circuits should ensure that their function can be automatically tested on a regular basis (at least two times a year).**

**INSTALLATION INSTRUCTIONS :**

- **Before installing the valves, clean and remove any objects from the pipes** (in particular bits of sealing and metal) which could obstruct and block the valves.
- **Ensure that both connecting pipes either side of the valve (upstream and downstream) are aligned (if they're not, the valves may not work correctly).**
- **Make sure that the two sections of the pipe (upstream and downstream) match, the valve unit will not absorb any gaps. Any distortions in the pipes may affect the tightness of the connection, the working of the valve and can even cause a rupture.** To be sure, place the kit in position to ensure the assembling will work.
- **During welding operation, for S.W. types half open the valve and do not exceed 350-400°C**
- The theoretical lengths given by ISO/R7 for the tapping are typically longer than required, the length of the thread should be limited, and **check that the end of the tube does not press right up to the head of the thread.**
- **Never use a vice to tighten the fixings of the valve.**
- **If sections of piping do not have their final support in place, they should be temporarily fixed. This is to avoid unnecessary strain on the valve.**
- **It may be necessary to screw the packing gland during using according to the type of use.**
- **Do not use a tool to shut the valve**
- **Fluids in the valve must not contain solid objects ( it could damaged the seat ).**
- **It's recommended to operate the valve ( open and close ) 1 to 2 times per year**